

RAY VE MİKNATISLAR

Aluminyum Rijit Ray, Bükülü Ring Ray, Aluminyum Yarı-Fleks Ray ve High-Fleks Ray

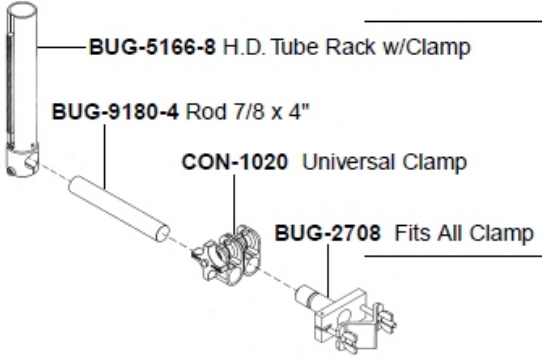

The addition of these 4 items provides a vertical racking motion for hand held guns.

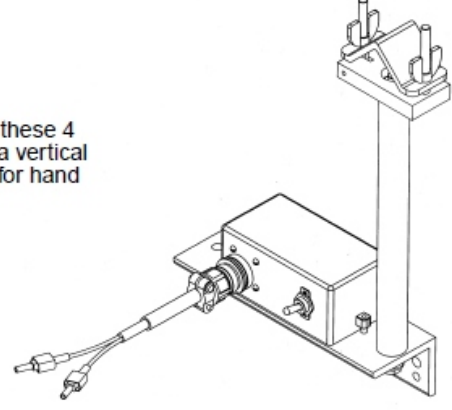

BUG-5485 Contactor/Cable Anchor:
Provides built-in contactor switch to control plasma or welding process. The Cable Anchor provides strain relief for all cables.

Rails & Attachments

ARR-1085 4' (1.18 m) Heavy Duty Rigid Rail
ARR-1080 8' (2.37 m) Heavy Duty Rigid Rail



**ARM-2505
Spacer Bar
for ARR Rail
only.**

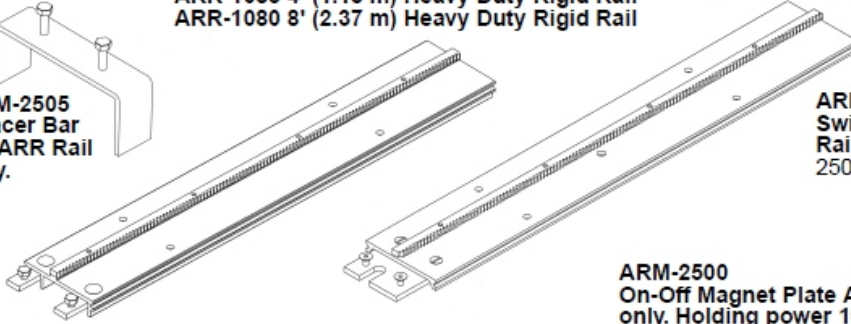

AFR-3000 Semi-Flex Rail can be bent inside or outside to a minimum radius of 15' (5.0 m) or 30' (10.0 m) diameter without permanent deformation.

**ARM-2425
Swivel Magnet for AFR-3000
Rail only.
250 lbs. Holding Power**

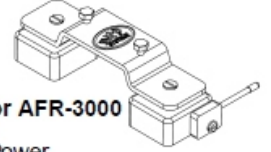

**ARM-2500
On-Off Magnet Plate Assembly for ARR Rail
only. Holding power 100 lbs. (45 kg)
Can be switched on and off for rapid set-up.**



Vacuum Systems For Non-Ferrous Metals

Standard Vacuum Support Kits:
ARV-1080 Vacuum Kit
For ARR-1080 & AFR-3000 Rails.
ARV-1085 Vacuum Kit
For ARR-1085 Rails.

Custom systems are required for Bent Rail.

ARV-1020 120 Volt/50-60 Hz
ARV-1030 220 Volt/50-60 Hz
The ARV-1020 (ARV-1030) Vacuum Pump
Kit is recommended for use with a maximum
of four (4) pieces of rail, or sixteen (16)
vacuum bars.



ARV-1085 Vacuum Kit for
ARR-1085 4' (102 mm) Rigid Rail.

ARV-1080 Vacuum Kit for
ARR-1080 8' (203 mm) Rigid Rail.

ARV-1080 Vacuum Kit for
AFR-3000 8' (203 mm) Semi-Flex Rail.

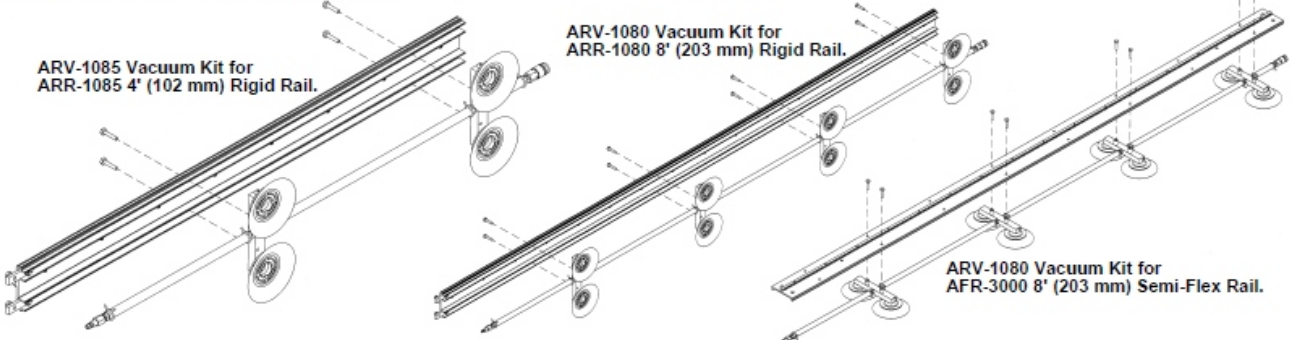

MARINE ENGINEERING

Adres: Yayla Mah. Vatan Cad. MEKA İş Merkezi No: 58 Kat:3 D.16
Tuzla - İSTANBUL / TURKEY

Tel: + 90 216 701 23 13 Fax: +90 216 701 23 14 Gsm: +90 532 506 39 59

web: www.marine-engineering.net